

MEKANİK TİP KAYICI TAKIM
WING TYPE SPLINE ASSEMBLY

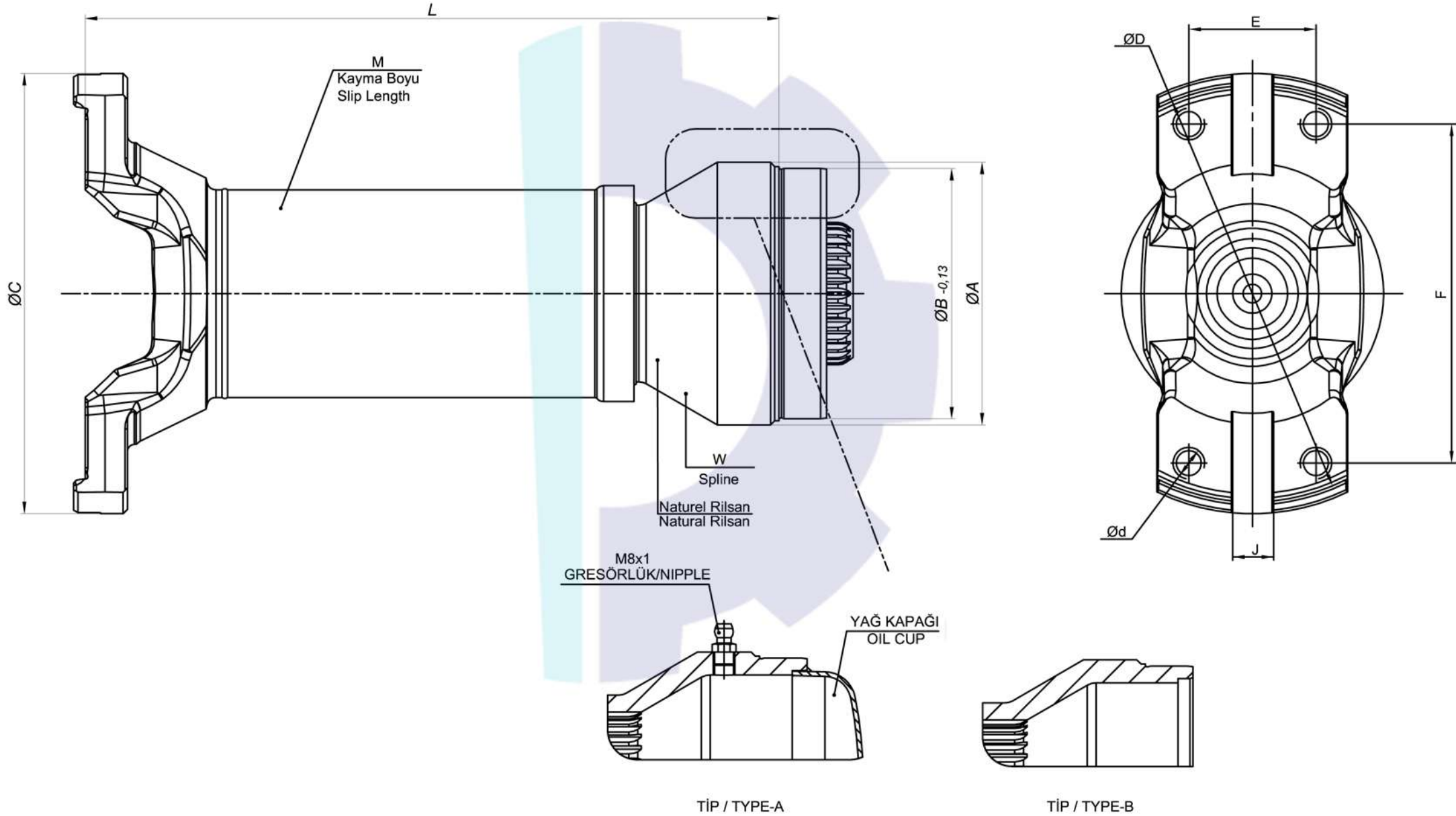

**MEKANİK TİP KAYICI TAKIM
WING TYPE SPLINE ASSEMBLY**

SERİ/SERIE	PARÇA/PART NO	TİP / TYPE	ØA	ØB	ØC	ØD	Ød	J	E	F	L	M	W	GRESÖRLÜK NIPPLE	BORU/TUBE
6C	SA.06000.02.02	A	88,5	84,4	148,4	140,46	3/8"x24 UNF-2B	14,26+0,04	42,9	114,3	234	120	Ø48x1,5x30°x30	M8x1	Ø88,9x2,4
	SA.06000.03.02	B	88,5	84,4	148,4	140,46	3/8"x24 UNF-2B	14,26+0,04	42,9	114,3	234	120	Ø48x1,5x30°x30	-	Ø88,9x2,4
	SA.06000.04.02	B	76,2	71,7	148,4	140,46	3/8"x24 UNF-2B	14,26+0,04	42,9	114,3	234	120	Ø48x1,5x30°x30	-	Ø76,2x2,4
7C	SA.07000.03.02	A	88,9	84,4	158	148,38	1/2"x20 UNF-2B	15,85+0,04	49,2	117,5	260	127	Ø55x2,5x30°x20	M8x1	Ø88,9x2,4
	SA.07000.04.02	A	88,9	83,1	158	148,38	1/2"x20 UNF-2B	15,85+0,04	49,2	117,5	260	127	Ø55x2,5x30°x20	M8x1	Ø88,9x3,05
	SA.07000.05.02	B	88,9	84,4	158	148,38	1/2"x20 UNF-2B	15,85+0,04	49,2	117,5	260	127	Ø55x2,5x30°x20	-	Ø88,9x2,4
	SA.07000.06.02	B	88,9	83,4	158	148,38	1/2"x20 UNF-2B	15,85+0,04	49,2	117,5	260	127	Ø55x2,5x30°x20	-	Ø88,9x3,05
	SA.07000.07.02	A	88	80,3	158	148,38	1/2"x20 UNF-2B	15,85+0,04	49,2	117,5	260	127	Ø55x2,5x30°x20	M8x1	Ø88x4
	SA.07000.08.02	B	88	80,3	158	148,38	1/2"x20 UNF-2B	15,85+0,04	49,2	117,5	260	127	Ø55x2,5x30°x20	-	Ø88x4
8,5C	SA.08500.01.02	A	101,6	95,1	175	165,1	1/2"x20 UNF-2B	15,85+0,04	71,42	123,8	280	120	Ø75x2,5x30°x28	M8x1	Ø101,6x3,4
	SA.08500.02.02	A	100	88,3	175	165,1	1/2"x20 UNF-2B	15,85+0,04	71,42	123,8	280	120	Ø75x2,5x30°x28	M8x1	Ø100x6
	SA.08500.03.02	B	101,6	95,1	175	165,1	1/2"x20 UNF-2B	15,85+0,04	71,42	123,8	280	120	Ø75x2,5x30°x28	-	Ø101,6x3,4
	SA.08500.04.02	B	100	88,3	175	165,1	1/2"x20 UNF-2B	15,85+0,04	71,42	123,8	280	120	Ø75x2,5x30°x28	-	Ø100x6
9C	SA.09000.01.02	B	115	100,3	223	209,52	1/2"x20 UNF-2B	15,85+0,04	71,42	168,8	354	180	Ø90x2,5x30°x34	-	Ø115x7,5
	SA.09000.02.02	A	115	100,3	223	209,52	1/2"x20 UNF-2B	15,85+0,04	71,42	168,8	354	180	Ø90x2,5x30°x34	M8x1	Ø115x7,5
	SA.09000.03.02	B	115	100,3	223	209,52	1/2"x20 UNF-2B	15,85+0,04	71,42	168,8	304	130	Ø90x2,5x30°x34	-	Ø115x7,5
	SA.09000.04.02	A	115	100,3	223	209,52	1/2"x20 UNF-2B	15,85+0,04	71,42	168,8	304	130	Ø90x2,5x30°x34	M8x1	Ø115x7,5

MEKANİK TİP KISA KARDAN MİLİ
WING TYPE SHORT COUPLE

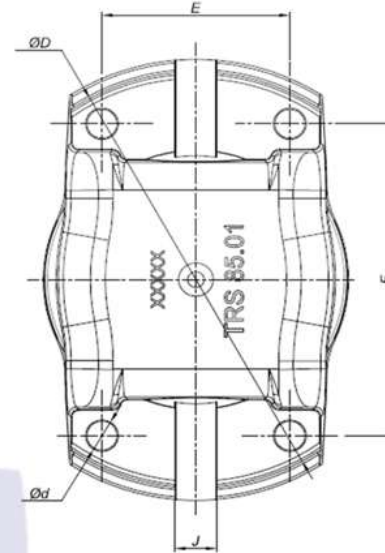
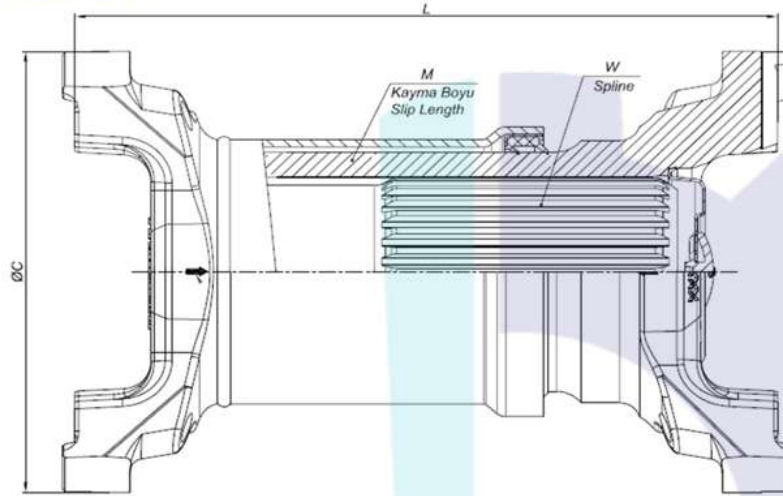

SERİ/SERIE	PARÇA/PART NO	ØC	ØD	E	F	Ød	J	L	M	W	MAFSAL AÇISI/JOINT ANGLE
6C	SC.06000.01.02	148,4	140,46+0.05	42,9	114,3	3/8"x24 UNF-2B	14,26+0.04	115	40	Ø48x1,5x30°x30	15°
	SC.06000.02.02	148,4	140,46+0.05	42,9	114,3	3/8"x24 UNF-2B	14,26+0.04	95	20	Ø48x1,5x30°x30	15°
	SC.09600.01.02	148,4	140,46+0.05	42,9	114,3	3/8"x24 UNF-2B	14,26+0.04	190	50	Ø48x1,5x30°x30	30°
	SC.09600.02.02	148,4	140,46+0.05	42,9	114,3	3/8"x24 UNF-2B	14,26+0.04	210	75	Ø48x1,5x30°x30	30°
	SC.09600.03.02	148,4	140,46+0.05	42,9	114,3	3/8"x24 UNF-2B	14,26+0.04	240	75	Ø48x1,5x30°x30	30°
	SC.09600.04.02	148,4	140,46+0.05	42,9	114,3	3/8"x24 UNF-2B	14,26+0.04	275	75	Ø48x1,5x30°x30	30°
SC.09600.06.02	148,4	140,46+0.05	42,9	114,3	3/8"x24 UNF-2B	14,26+0.04	290	120	Ø48x1,5x30°x30	30°	
7C	SC.09700.01.02	158	148,38+0.05	49,2	117,5	1/2"-20 UNF-2B	15,85+0.04	190	50	Ø55x2,5x30°x20	25°
	SC.09700.02.02	158	148,38+0.05	49,2	117,5	1/2"-20 UNF-2B	15,85+0.04	227	75	Ø55x2,5x30°x20	25°
	SC.09700.03.02	158	148,38+0.05	49,2	117,5	1/2"-20 UNF-2B	15,85+0.04	268	80	Ø55x2,5x30°x20	25°
	SC.09700.04.02	158	148,38+0.05	49,2	117,5	M12	15,85+0.04	268	80	Ø55x2,5x30°x20	25°
	SC.09700.05.02	158	148,38+0.05	49,2	117,5	1/2"-20 UNF-2B	15,85+0.04	308	80	Ø55x2,5x30°x20	25°
	SC.09700.09.02	158	148,38+0.05	49,2	117,5	1/2"-20 UNF-2B	15,85+0.04	320	155	Ø55x2,5x30°x20	25°
8,5C	SC.09850.01.02	175	165,1+0.05	71,42	123,8	1/2"-20 UNF-2B	15,85+0.04	258,5	85	Ø75x2,5x30°x28	25°
	SC.09850.02.02	175	165,1+0.05	71,42	123,8	1/2"-20 UNF-2B	15,85+0.04	208	65	Ø75x2,5x30°x28	25°
	SC.09850.03.02	175	165,1+0.05	71,42	123,8	1/2"-20 UNF-2B	15,85+0.04	267	85	Ø75x2,5x30°x28	25°
	SC.09850.04.02	175	165,1+0.05	71,42	123,8	1/2"-20 UNF-2B	15,85+0.04	239	65	Ø75x2,5x30°x28	25°
	SC.09850.05.02	175	165,1+0.05	71,42	123,8	1/2"-20 UNF-2B	15,85+0.04	223	75	Ø75x2,5x30°x28	25°

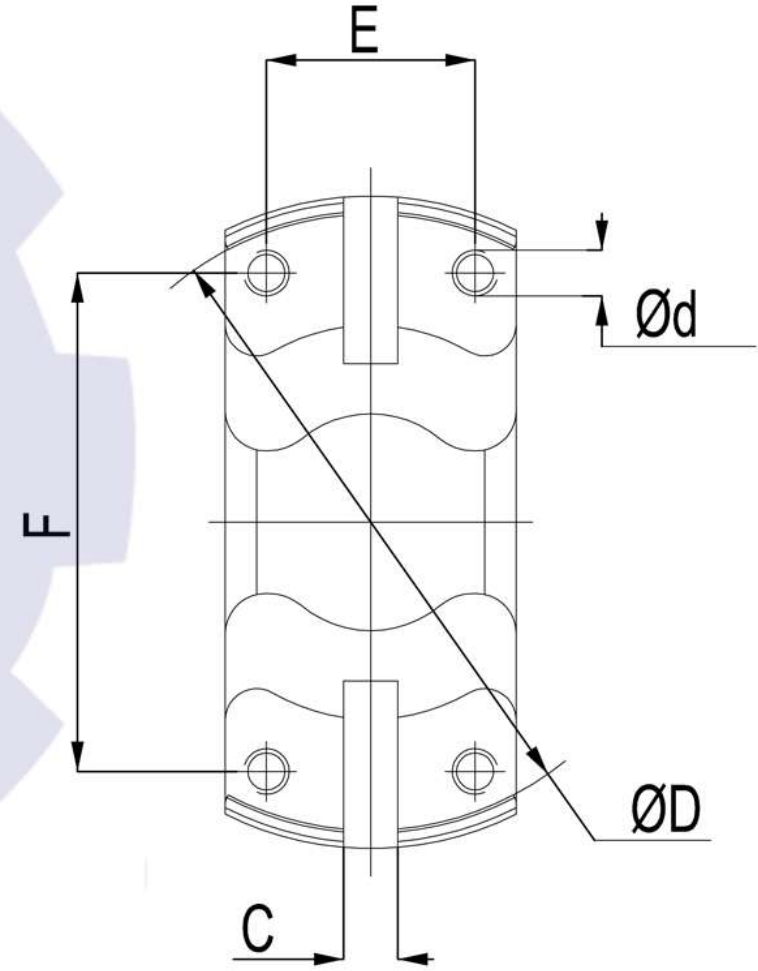
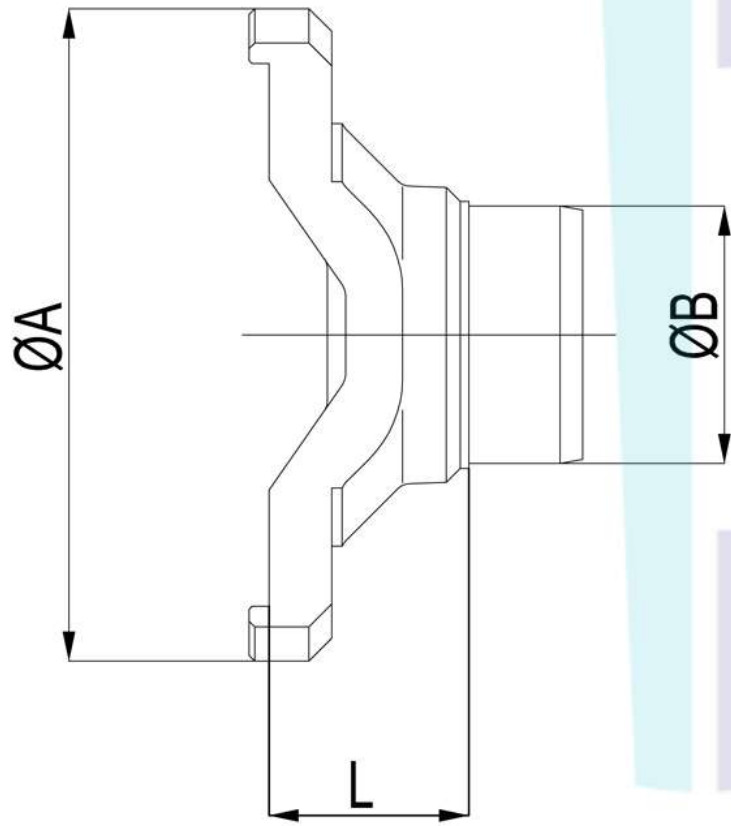

SERİ/SERIE	PARÇA/PART NO	ØA	ØB	C	ØD	E	F	Ød	L	BORU/TUBE
6C	TY.06000.05.02	148,4	71,7	14,26	140,46	42,9	114,3	3/8"-24 UNF-2B	47,6	Ø76,2x2,4
	TY.06000.06.02	148,4	84,4	14,26	140,46	42,9	114,3	3/8"-24 UNF-2B	47,6	Ø88,9x2,4

7C	TY.07000.05.02	158	83,1	15,85	148,38	49,2	117,5	1/2"-20 UNF-2B	53,85	Ø88,9x3,05
	TY.07000.06.02	158	84,4	15,85	148,38	49,2	117,5	1/2"-20 UNF-2B	53,85	Ø88,9x2,4
	TY.07000.07.02	158	80,3	15,85	148,38	49,2	117,5	1/2"-20 UNF-2B	53,85	Ø88x4

8,5C	TY.08500.01.02	175	95,1	15,85	165,1	71,42	123,8	1/2"-20 UNF-2B	66,5	Ø101,6x3,4
	TY.08500.02.02	175	88,3	15,85	165,1	71,42	123,8	1/2"-20 UNF-2B	66,5	Ø100x6

9C	TY.09000.01.02	223	100,3	15,85	209,52	71,42	168,28	1/2"-20 UNF-2B	75	Ø115x7,5
----	----------------	-----	-------	-------	--------	-------	--------	----------------	----	----------